



Hidrotema



Hidrotema

1. SAFETY PRECAUTIONS

The user, through its own analysis and testing, is solely responsible for determining the suitability of Taimi products for his own usage. The user must also assure compatibility of the swivel's seals with the fluid used. Never modify or weld on a Taimi product. Taimi products should never be used as structural or load bearing components. Always design all systems and equipment in a fail-safe mode, so that failure will not endanger persons or property.

MAXIMUM WORKING PRESSURE - CARTRIDGES & STANDARD SERIES

SIZES	PSI	Bar
06 - 08 - 10 - 12 - 16	6250	430
20	5600	386
24	4500	310
32	3000	205

MAXIMUM WORKING PRESSURE - 90° SHORT SERIES SWIVELS

SIZES	PSI	Bar
06 - 08	5000	345
12	4000	276
16	3500	241
20	2500	172

When assembling or doing maintenance on hydraulic systems and hose assemblies, it is of uttermost importance to be properly trained, use appropriate tools, components and equipment, follow specifications and think safety. Failure to follow safety precautions or improper product use can cause death, personal injury and property damage. Always relieve pressure before dismantling hydraulic lines.

Pressure capabilities of Taimi products must be respected. Temperatures below and above the recommended limit can affect seals to a point where a failure may occur and pressurized fluid be released.

Seals deteriorate over time and should be replaced at specific intervals, based on previous service life, fluid used and industry recommendations, or when failures could result in unacceptable downtime, damage, or injury risk. Only use Taimi original seals. It is important to assemble Taimi cartridges according to the torque charts. If Taimi cartridges are overtorqued, a housing failure may happen over time causing serious injuries or death. An undertorqued cartridge may dismantle causing serious injuries or death. Visually inspect your Taimi products for evidence of leakage, wear, or damage. Replace damaged products immediately.



WARNING : This product can expose you to chemicals including cobalt, which is known to the State of California to cause cancer. For more information, go to www.P65warnings.ca.gov





2. TECHNOLOGY

Taimi's unique ball-less swivel products bring reliability to your hydraulic systems, increasing service life and cutting out leakages. This translates in higher productivity and lower operating costs.

Our exclusive shank-nut assembly (cartridge) is the key to the effectiveness of our design.

The long span of the shank and the large contact surfaces allow for optimal load distribution. The slick thrust washer is built out of a self-lubricating polymer yielding low friction performance and excellent shock absorption characteristics.

- (A) The sturdy nut securely fastens the rotating shank to a housing, a block or a manifold, and prevents it from ever dismantling during operation.
- (B) Superior sealing is achieved in 3 stages; first by two (2) sets of oversized Viton o-rings and Teflon backups and by the contact under pressure on our thrust washer, effectively protecting against pressure spikes, for an unmatched reliability.

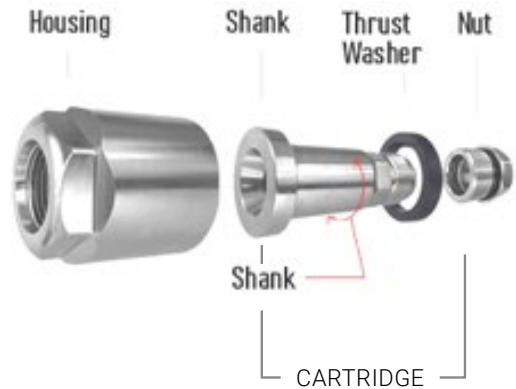

IMPULSE CYCLES TO FAILURE (INDEPENDANT TEST)



3. RESEARCH & DEVELOPMENT

Our technical staff works together with manufacturers, users, and machine operators. We develop our products to meet their needs.

We offer in-person and remote support to design and test new applications that meet your specific requirements. Technical drawings of our applications are available upon request.

CONTACT US TO DISCUSS YOUR SPECIFIC NEEDS AND THE POSSIBILITY OF MANUFACTURING A CUSTOM SOLUTION.

Our promises are to help you improve your productivity, reduce your operating costs, and help protect the environment by reducing leakage.

WE ARE GUIDED BY THESE VALUES :

INNOVATION

EXCELLENCY

COLLABORATION

CLIENT SATISFACTION

SUSTAINABILITY





4. CARTRIDGE SWIVELS

The Cartridge Swivel is designed to be integrated into hydraulic manifolds. It simply screws in, becoming a short and very sturdy swivel port that will live through high pressure and side loads.

WHY CHOOSE TAIMI CARTRIDGE SWIVELS ?

- **Pressure Spikes Protection™**
- **Easy and quick to repack**
- **Triple Seal Protection™**
- **Patented ball-less design**
- **Cannot be pulled apart**
- **Less expensive than a stand alone hose swivel**
- **Easy integration**
- **Custom solutions available**
- **Technical support**



Hidrotema



THE TOUGHEST SWIVEL PRODUCTS ON THE MARKET

HOW TO ORDER

SZ4	12	J	01	M
CARTRIDGE SWIVEL DESIGNATOR	HOSE CONNECTION SIZE	HOSE CONNECTION TYPE J = JIC (37°) F = NPT P = BSPP S = ORFS M = Metric	ASSEMBLY NUMBER	SHANK CONFIGURATION M = MALE

Part numbers in orange
are usually in stock.

Other products are
manufactured to order.



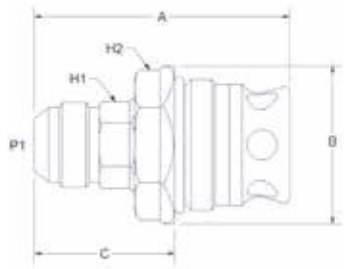

SIDE FEED CARTRIDGE MALE JIC - 37° FLARE

PART NU.	A	B	C	P1	H1	H2	SEAL KIT
SZ4-12-J10M	3.19"	1.97"	1.75"	1 1/16"-12 UN	15/16"	1 5/8"	SZ-12-110SK-A
SZ4-16-J10M	3.47"	2.22"	1.94"	1 5/16"-12 UN	1 3/16"	1 7/8"	SZ-16-110SK-A

MALE JIC - 37° FLARE

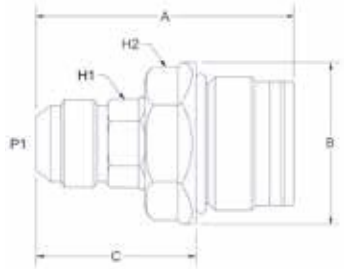

PART NU.	A	B	C	P1	H1	H2	SEAL KIT
SZ4-06-J01M	1.99"	1.22"	1.21"	9/16"-18 UNF	1/2"	1"	SZ-06-001SK-A
SZ4-08-J01M	2.53"	1.47"	1.56"	3/4"-16 UNF	11/16"	1 1/4"	SZ-08-001SK-A
SZ4-10-J01M	2.59	1.72	1.63	7/8"-14 UNF	13/16"	1 1/2"	SZ-10-001SK-A
SZ4-12-J01M	3.15"	1.97"	1.95"	1 1/16"-12 UN	15/16"	1 5/8"	SZ-12-001SK-A
SZ4-16-J01M	3.63"	2.22"	2.38"	1 5/16"-12 UN	1 3/16"	1 7/8"	SZ-16-001SK-A
SZ4-20-J01M	3.96"	2.75"	2.55"	1 5/8"-12 UN	1 1/2"	2 3/8"	SZ-20-001SK-A
SZ4-24-J01M	4.17"	2.97"	2.68"	1 7/8"-12 UN	1 3/4"	2 1/2"	SZ-24-001SK-A
SZ4-32-J01M	5.03"	3.88"	3.28"	2 1/2"-12 UN	2 5/16"	3 1/4"	SZ-32-001SK-A

MALE PIPE (NPT)

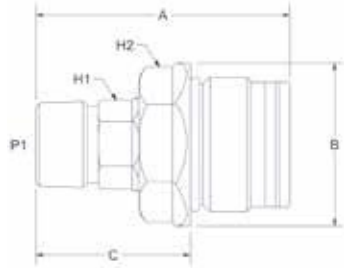

PART NU.	A	B	C	P1	H1	H2	SEAL KIT
SZ4-06-F01M	1.93"	1.35"	1.17"	3/8" NPT	5/8"	1 1/8"	SZ-06-002SK-A
SZ4-08-F01M	2.38"	1.53"	1.41"	1/2" NPT	3/4"	1 5/16"	SZ-08-002SK-A
SZ4-12-F01M	3.06"	1.97"	1.86"	3/4" NPT	15/16"	1 5/8"	SZ-12-001SK-A
SZ4-16-F01M	3.25"	2.22"	2.00"	1" NPT	1 3/16"	1 7/8"	SZ-16-001SK-A
SZ4-20-F01M	3.63"	2.72"	2.22"	1 1/4" NPT	1 1/2"	2 3/8"	SZ-20-001SK-A

MALE BSPP

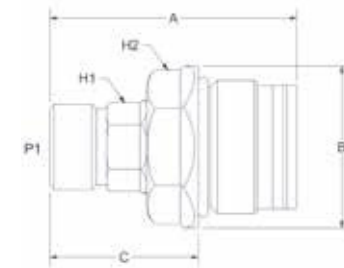

PART NU.	A	B	C	P1	H1	H2	SEAL KIT
SZ4-08-P01M	2.36"	1.53"	1.39"	G 1/2	3/4"	1 5/16"	SZ-08-002SK-A
SZ4-12-P01M	3.00"	1.97"	1.86"	G 3/4	15/16"	1 5/8"	SZ-12-001SK-A
SZ4-16-P01M	3.50"	2.22"	2.25"	G 1	1 3/16"	1 7/8"	SZ-16-001SK-A
SZ4-20-P01M	3.63"	2.72"	2.25"	G 1 1/4	1 1/2"	2 3/8"	SZ-20-001SK-A



MALE ORFS (O-RING FACE SEAL / FLAT FACE O-RING)

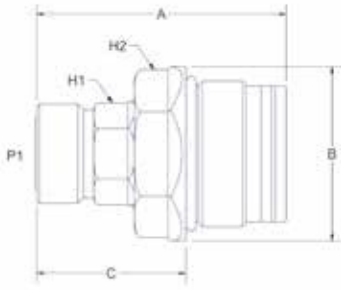

PART NU.	A	B	C	P1	H1	H2	SEAL KIT
SZ4-06-S01M	1.83"	1.35"	1.07"	11/16" - 16 UNF	5/8"	1 1/8"	SZ-06-002SK-A
SZ4-08-S01M	2.41"	1.53"	1.44"	13/16" - 16 UNF	3/4"	1 5/16"	SZ-08-002SK-A
SZ4-10-S01M	2.51"	1.86"	1.55"	1" - 14 UNF	15/16"	1 5/8"	SZ-10-002SK-A
SZ4-12-S01M	3.06"	2.09"	1.86"	1 3/16" - 12 UN	1 1/16"	1 3/4"	SZ-12-002SK-A
SZ4-16-S01M	3.50"	2.31"	2.25"	1 7/16" - 12 UN	1 5/16"	2"	SZ-16-002SK-A
SZ4-20-S01M	3.69"	2.72"	2.29"	1 11/16" - 12 UN	1 9/16"	2 3/8"	SZ-20-002SK-A
SZ4-24-S01M	3.91"	3.19"	2.42"	2.00" - 12 UN	1 7/8"	2 3/4"	SZ-24-002SK-A

MALE METRIC (DIN 3852)

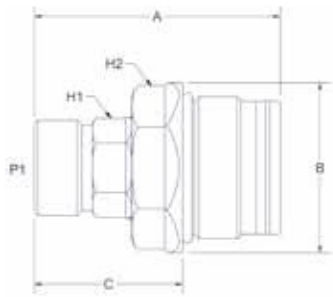

PART NU.	A	B	C	P1	H1	H2	SEAL KIT
SZ4-20S-M01M	2.38"	1.53"	1.43"	M20 X 1,5	3/4"	1 5/16"	SZ-08-002SK-A
SZ4-24S-M01M	2.56"	1.86"	1.57"	M24 X 1.5	15/16"	1 5/8"	SZ-10-002SK-A
SZ4-30S-M01M	3.03"	2.09"	1.83"	M30 X 2.0	1 1/16"	1 3/4"	SZ-12-002SK-A
SZ4-36S-M01M	3.46"	2.41"	2.21"	M36 X 2.0	1 5/16"	2"	SZ-16-002SK-A
SZ4-42S-M01M	3.72"	2.72"	2.32"	M42 X 2.0	1 9/16"	2 3/8"	SZ-20-002SK-A



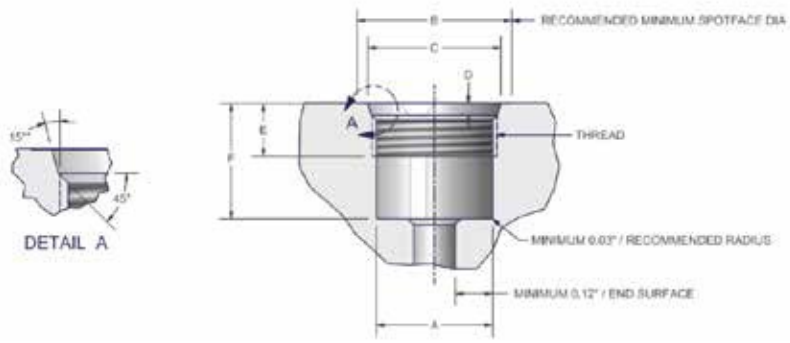

CARTRIDGES BORING DIMENSIONS CHART

DIMENSIONS IN INCHES

SIZES & CONFIGURATION	A	B	C	D	E	F	THREAD
J06	0.920"-0.925"	1.28"	1.068"-1.073"	0.100"-0.105"	0.50"-0.53"	0.800"-0.810"	1.00" - 12 UN - 1B
P06, S06, M18, F06	1.045"-1.050"	1.38"	1.183"-1.188"	0.100"-0.105"	0.50"-0.53"	0.800"-0.810"	1.12" - 12 UN - 1B
J08	1.170"-1.175"	1.53"	1.310"-1.315"	0.100"-0.105"	0.69"-0.72"	1.000"-1.010"	1.25" - 12 UN - 1B
P08, S08, M20, F08	1.235"-1.240"	1.56"	1.373"-1.378"	0.100"-0.105"	0.69"-0.72"	1.000"-1.010"	1.31" - 12 UN - 1B
J10, P10, F10	1.355"-1.360"	1.78"	1.520"-1.525"	0.100"-0.105"	0.69"-0.72"	1.000"-1.010"	1.44" - 12 UN - 1B
S10, M24	1.490"-1.495"	1.94"	1.645"-1.650"	0.125"-0.130"	0.69"-0.72"	1.000"-1.010"	1.56" - 12 UN - 1B
J12, P12, F12	1.545"-1.550"	2.03"	1.690"-1.695"	0.125"-0.130"	0.81"-0.84"	1.235"-1.245"	1.63" - 12 UN - 1B
S12, M30	1.670"-1.675"	2.13"	1.860"-1.865"	0.125"-0.130"	0.81"-0.84"	1.235"-1.245"	1.75" - 12 UN - 1B
J16, P16, F16	1.795"-1.800"	2.25"	1.940"-1.945"	0.125"-0.130"	0.81"-0.84"	1.285"-1.295"	1.88" - 12 UN - 1B
S16, M36	1.915"-1.920"	2.38"	2.107"-2.112"	0.125"-0.130"	0.81"-0.84"	1.285"-1.295"	2.00" - 12 UN - 1B
J20, P20, S20, M42, F20	2.295"-2.300"	2.78"	2.430"-2.435"	0.125"-0.130"	1.00"-1.03"	1.440"-1.450"	2.38" - 12 UN - 1B
J24, F24	2.545"-2.550"	3.03"	2.690"-2.695"	0.125"-0.130"	1.00"-1.03"	1.530"-1.540"	2.63" - 12 UN - 1B
S24	2.660"-2.665"	3.21"	2.815"-2.820"	0.125"-0.130"	1.00"-1.03"	1.530"-1.540"	2.75" - 12 UN - 1B
J32, F32	3.295"-3.300"	3.94"	3.460"-3.465"	0.125"-0.130"	1.12"-1.15"	1.790"-1.800"	3.38" - 12 UN - 1B

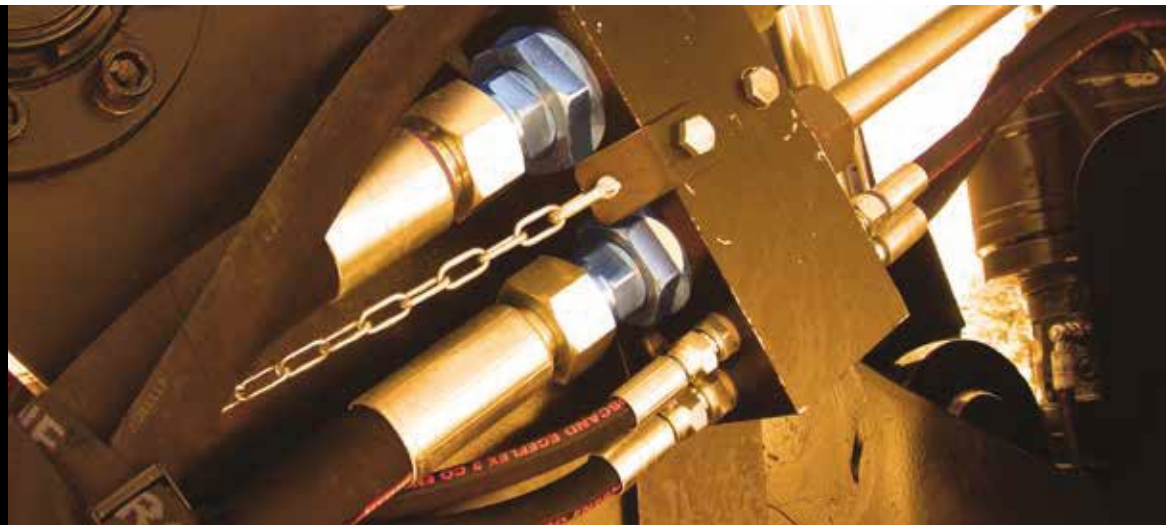

CARTRIDGES BORING DIMENSIONS CHART

METRIC DIMENSIONS

SIZES & CONFIGURATION	A	B	C	D	E	F	THREAD
J06	23.368-23.495	32.5	27.127-27.254	2.540-2.667	12.7-13.46	20.32-20.57	1.00" - 12 UN - 1B
P06, S06, M18, F06	26.543-26.670	35.0	30.048-30.175	2.540-2.667	12.7-13.46	20.32-20.57	1 1/8" - 12 UN - 1B
J08	29.718-29.845	38.9	33.274-33.401	2.540-2.667	17.53-18.29	25.40-25.65	1 1/4" - 12 UN - 1B
P08, S08, M20, F08	31.369-31.496	39.7	34.874-35.001	2.540-2.667	17.53-18.29	25.40-25.65	1 5/16" - 12 UN - 1B
J10, P10, F10	34.417-34.544	45.2	38.608-38.735	2.540-2.667	17.53-18.29	25.40-25.65	1 7/16" - 12 UN - 1B
S10, M24	37.846-37.973	49.3	41.783-41.910	3.175-3.302	17.53-18.29	25.40-25.65	1 9/16" - 12 UN - 1B
J12, P12, F12	39.243-39.370	51.6	42.926-43.053	3.175-3.302	20.57-21.34	31.37-31.62	1 5/8" - 12 UN - 1B
S12, M30	42.418-42.545	54.1	47.244-47.371	3.175-3.302	20.57-21.34	31.37-31.62	1 3/4" - 12 UN - 1B
J16, P16, F16	45.593-45.720	57.2	49.276-49.403	3.175-3.302	20.57-21.34	32.64-32.90	1 7/8" - 12 UN - 1B
S16, M36	48.641-48.768	60.5	53.518-53.645	3.175-3.302	20.57-21.34	32.64-32.90	2.00" - 12 UN - 1B
J20, P20, S20, M42, F20	58.293-58.420	70.6	61.722-61.849	3.175-3.302	25.40-26.16	36.58-36.83	2 3/8" - 12 UN - 1B
J24, F24	64.643-64.770	77.0	68.326-68.453	3.175-3.302	25.40-26.16	38.86-39.12	2 5/8" - 12 UN - 1B
S24	67.564-67.691	81.5	71.501-71.628	3.175-3.302	25.40-26.16	38.86-39.12	2 3/4" - 12 UN - 1B
J32, F32	83.693-83.820	100.0	87.884-88.011	3.175-3.302	28.45-29.21	45.47-45.72	3 3/8" - 12 UN - 1B

SHANK INTERCHANGE

SIZES	JIC	BSPP	NPT	ORFS
06	X	✓	✓	✓
08	X	✓	✓	✓
10	✓	✓	na	X
12	✓	✓	✓	X
16	✓	✓	✓	X
20	✓	✓	✓	✓
24	✓	na	✓	na
32	✓	na	✓	na

CARTRIDGE SWIVEL ASSEMBLY TORQUE

SIZES	FT-LBS	NM
06	125	170 Nm
08	215	290 Nm
10	300	405 Nm
12	390	530 Nm
16	490	665 Nm
20	800	1080 Nm
24	900	1215 Nm
32	1000	1350 Nm





5. IN-LINE SWIVELS

Taimi's patented ball-less swivels bring reliability to your hydraulic system increasing service life and cutting out leakages. This means higher productivity and lower operating costs. Taimi's swivels are the toughest on the market and are being chosen by some of the largest machinery manufacturers worldwide.

WHY CHOOSE TAIMI IN-LINE SWIVELS?

- **Pressure Spikes Protection™**
- **Easy and quick to repack**
- **Triple Seal Protection™**
- **Patented ball-less design**
- **Cannot be pulled apart**
- **Withstand high pressures and harsh environments**
- **Custom solutions available**



HYDRAULIC PEACE OF MIND

Part numbers in orange
are usually in stock.

Other products are
manufactured to order

HOW TO ORDER

SZ	J	12	M	J	12	M
SWIVEL DESIGNATOR	HOSE CONNECTION TYPE J = JIC (37°) F = NPT P = BSPP S = ORFS M = Metric	SHANK SIZE	SHANK CONFIGURATION M = MALE	HOUSING HOSE CONNECTION TYPE J = JIC (37°) FLARE JB = COMBO JIC 37° FLARE - SAE (O-RING BOSS) F = NPT P = BSPP S = ORFS (O-RING FACE SEAL) M = METRIC	HOUSING 1/16 of an inch M = MALE F = FEMALE	HOUSING CONFIGURATION M = MALE F = FEMALE



MALE JIC (37° FLARE) - MALE JIC (37° FLARE)

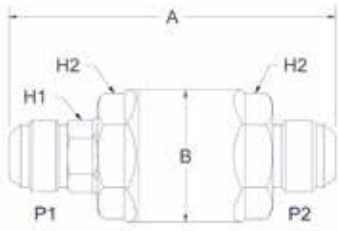

PART NU.	A	B	P1	P2	H1	H2	SEAL KIT
SZ-J06M-J06M	2.94"	1.23"	9/16" - 18 UNF	9/16" - 18 UNF	1/2"	1"	SZ-06-001SK-A
SZ-J08M-J08M	3.88"	1.47"	3/4" - 16 UNF	3/4" - 16 UNF	11/16"	1 1/4"	SZ-08-001SK-A
SZ-J12M-J12M	4.94"	1.97"	1 1/16"- 12 UN	1 1/16"- 12 UN	15/16"	1 5/8"	SZ-12-001SK-A
SZ-J16M-J16M	5.56"	2.22"	1 5/16"- 12 UN	1 5/16"- 12 UN	1 3/16"	1 7/8"	SZ-16-001SK-A
SZ-J20M-J20M	6.06"	2.72"	1 5/8"- 12 UN	1 5/8"- 12 UN	1 1/2"	2 3/8"	SZ-20-001SK-A
SZ-J24M-J24M	6.44"	2.97"	1 7/8"- 12 UN	1 7/8"- 12 UN	1 3/4"	2 1/2"	SZ-24-001SK-A

MALE JIC (37° FLARE) - COMBO - FEMALE JIC (37° FLARE) /
FEMALE O-RING BOSS (ORB) / SAE J1926-3

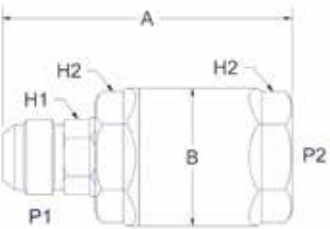

PART NU.	A	B	P1	P2	H1	H2	SEAL KIT
SZ-J06M-JB06F	2.59"	1.23"	9/16 - 18 UNF	9/16 - 18 UNF	1/2"	1"	SZ-06-001SK-A
SZ-J08M-JB08F	3.31"	1.47"	3/4" - 16 UNF	3/4" - 16 UNF	11/16"	1 1/4"	SZ-08-001SK-A
SZ-J10M-JB10F	3.45"	1.73"	7/8" - 14 UNF	7/8" - 14 UNF	13/16"	1 1/2"	SZ-10-001SK-A
SZ-J12M-JB12F	4.12"	1.97"	1 1/16"- 12 UN	1 1/16"- 12 UN	15/16"	1 5/8"	SZ-12-001SK-A
SZ-J16M-JB16F	4.63"	2.22"	1 5/16"- 12 UN	1 5/16"- 12 UN	1 3/16"	1 7/8"	SZ-16-001SK-A
SZ-J20M-JB20F	5.12"	2.72"	1 5/8"- 12 UN	1 5/8"- 12 UN	1 1/2"	2 3/8"	SZ-20-001SK-A
SZ-J24M-JB24F	5.34"	2.97"	1 7/8"- 12 UN	1 7/8"- 12 UN	1 3/4"	2 1/2"	SZ-24-001SK-A
SZ-J32M-JB32F	6.50"	3.88"	2 1/2"- 12 UN	2 1/2"- 12 UN	2 5/16"	3 1/4"	SZ-32-001SK-A



MALE JIC (37° FLARE) - FEMALE PIPE (NPT)

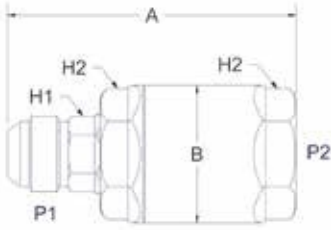

PART NU.	A	B	P1	P2	H1	H2	SEAL KIT
SZ-J08M-F08F	3.31"	1.50"	3/4" - 16 UNF	1/2" NPT	11/16"	1 1/4"	SZ-08-001SK-A
SZ-J12M-F12F	4.19"	2.00"	1 1/16"- 12 UN	3/4" NPT	15/16"	1 5/8"	SZ-12-001SK-A
SZ-J16M-F16F	4.88"	2.22"	1 5/16"- 12 UN	1" NPT	1 3/16"	1 7/8"	SZ-16-001SK-A
SZ-J20M-F20F	5.37"	2.75"	1 5/8"- 12 UN	1 1/4" NPT	1 1/2"	2 3/8"	SZ-20-001SK-A

MALE JIC (37° FLARE) - FEMALE BSPP

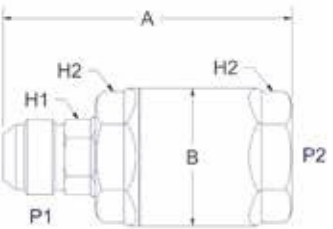

PART NU.	A	B	P1	P2	H1	H2	SEAL KIT
SZ-J12M-P12F	4.19"	1.97"	1 1/16"- 12 UN	G 3/4	15/16"	1 5/8"	SZ-12-001SK-A
SZ-J16M-P16F	4.88"	2.72"	1 5/16"- 12 UN	G 1	1 3/16"	1 7/8"	SZ-16-001SK-A

MALE JIC (37° FLARE) - MALE BSPP

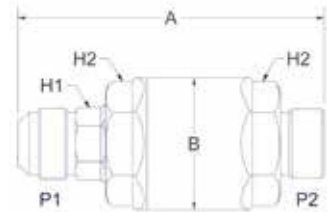

PART NU.	A	B	P1	P2	H1	H2	SEAL KIT
SZ-J12M-P12M	4.19"	1.97"	1 1/16"- 12 UN	G 3/4	15/16"	1 5/8"	SZ-12-001SK-A
SZ-J16M-P16M	4.88"	2.22"	1 5/16"- 12 UN	G 1	1 3/16"	1 7/8"	SZ-16-001SK-A



MALE PIPE (NPT) - FEMALE PIPE (NPT)

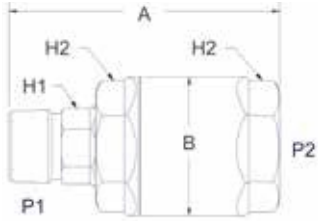

PART NU.	A	B	P1	P2	H1	H2	SEAL KIT
SZ-F08M-F08F	3.00"	1.53"	1/2" NPT	1/2" NPTF	3/4"	1 5/16"	SZ-08-002SK-A
SZ-F12M-F12F	3.88"	1.97"	3/4" NPT	3/4" NPTF	15/16"	1 5/8"	SZ-12-001SK-A
SZ-F16M-F16F	4.12"	2.22"	1" NPT	1" NPTF	1 3/16"	1 7/8"	SZ-16-001SK-A
SZ-F20M-F20F	4.88"	2.72"	1 1/4" NPT	1 1/4" NPTF	1 1/2"	2 3/8"	SZ-20-001SK-A

MALE PIPE (NPT) - COMBO FEMALE JIC (37° FLARE) / FEMALE O-RING BOSS (ORB) / SAE J1926-3

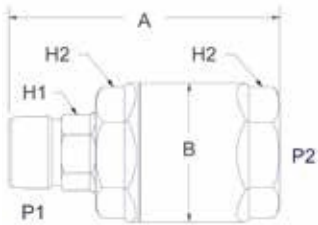

PART NU.	A	B	P1	P2	H1	H2	SEAL KIT
SZ-F12M-JB12F	3.88"	1.97"	3/4 NPT	1 1/16"- 12 UN	15/16"	1 5/8"	SZ-12-001SK-A
SZ-F16M-JB16F	4.12"	2.22"	1 NPT	1 5/16"- 12 UN	1 3/16"	1 7/8"	SZ-16-001SK-A
SZ-F20M-JB20F	4.88"	2.72"	1 1/4 NPT	1 5/8"- 12 UN	1 1/2"	2 3/8"	SZ-20-001SK-A

MALE BSPP - MALE BSPP

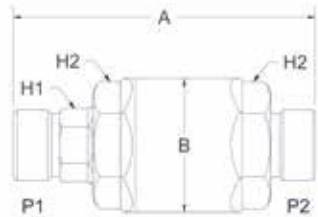

PART NU.	A	B	P1	P2	H1	H2	SEAL KIT
SZ-P08M-P08M	3.44"	1.53"	G 1/2	G 1/2	3/4"	1 5/16"	SZ-08-002SK-A
SZ-P12M-P12M	4.52"	1.97"	G 3/4	G 3/4	15/16"	1 5/8"	SZ-12-001SK-A
SZ-P16M-P16M	5.06"	2.22"	G 1	G 1	1 3/16"	1 7/8"	SZ-16-001SK-A



MALE BSPP - FEMALE BSPP

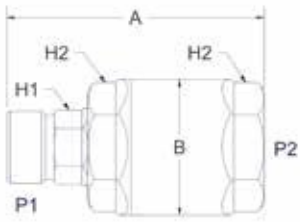

PART NU.	A	B	P1	P2	H1	H2	SEAL KIT
SZ-P08M-P08F	2.94"	1.53"	G 1/2	G 1/2	3/4"	1 5/16"	SZ-08-002SK-A
SZ-P12M-P12F	3.81"	1.97"	G 3/4	G 3/4	15/16"	1 5/8"	SZ-12-001SK-A
SZ-P16M-P16F	4.31"	2.22"	G 1	G 1	1 3/16"	1 7/8"	SZ-16-001SK-A
SZ-P20M-P20F	4.50"	2.72"	G 1 1/4	G 1 1/4	1 1/2"	2 3/8"	SZ-20-001SK-A

MALE ORFS (O-RING FACE SEAL) - MALE ORFS (O-RING FACE SEAL)

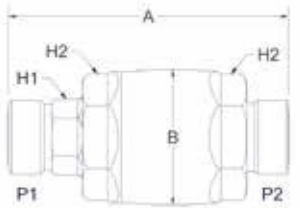

PART NU.	A	B	P1	P2	H1	H2	SEAL KIT
SZ-S06M-S06M	2.77"	1.35"	11/16"-16 UNF	11/16" - 16 UNF	5/8"	1 1/8"	SZ-06-002SK-A
SZ-S08M-S08M	3.50"	1.53"	13/16" - 16 UNF	13/16" - 16 UNF	3/4"	1 5/16"	SZ-08-002SK-A
SZ-S10M-S10M	3.79"	1.86"	1" - 14 UNS	1" - 14 UNS	15/16"	1 5/8"	SZ-10-002SK-A
SZ-S12M-S12M	4.52"	2.09"	1 3/16"- 12 UN	1 3/16"- 12 UN	1 1/16"	1 3/4"	SZ-12-002SK-A
SZ-S16M-S16M	5.12"	2.31"	1 7/16"- 12 UN	1 7/16"- 12 UN	1 5/16"	2"	SZ-16-002SK-A
SZ-S20M-S20M	5.46"	2.72"	1 11/16"- 12 UN	1 11/16"- 12 UN	1 9/16"	2 3/8"	SZ-20-002SK-A

MALE ORFS (O-RING FACE SEAL) - COMBO FEMALE JIC (37° FLARE) / FEMALE O-RING BOSS (ORB) / SAE J1926-3

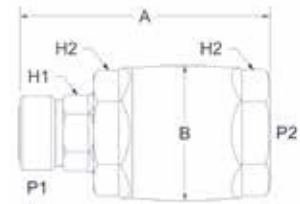

PART NU.	A	B	P1	P2	H1	H2	SEAL KIT
SZ-S12M-JB12F	3.86"	2.09"	1 3/16"- 12 UN	1 1/16" - 12 UN	1 1/16"	1 3/4"	SZ-12-002SK-A
SZ-S16M-JB16F	4.38"	2.31"	1 7/16"- 12 UN	1 5/16" - 12 UN	1 5/16"	2"	SZ-16-002SK-A
SZ-S20M-JB20F	4.68"	2.72"	1 11/16"- 12 UN	1 5/8" - 12 UN	1 9/16"	2 3/8"	SZ-20-002SK-A

MALE ORFS (O-RING FACE SEAL) - FEMALE ORFS (O-RING FACE SEAL)

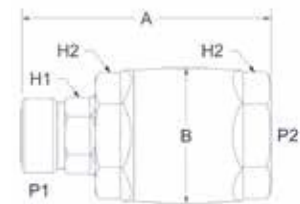

PART NU.	A	B	P1	P2	H1	H2	SEAL KIT
SZ-S08M-S08F	3.00"	1.53"	13/16" - 16 UNF	13/16" - 16 UNF	3/4"	1 5/16"	SZ-08-002SK-A
SZ-S10M-S10F	3.78"	1.85"	1" - 14 UNF	1" - 14 UNF	15/16"	1 5/8"	SZ-10-002SK-A
SZ-S12M-S12F	3.86"	2.09"	1 3/16"- 12 UN	1 3/16"- 12 UN	1 1/16"	1 3/4"	SZ-12-002SK-A
SZ-S16M-S16F	4.38"	2.31"	1 7/16"- 12 UN	1 7/16"- 12 UN	1 5/16"	2"	SZ-16-002SK-A
SZ-S20M-S20F	4.68"	2.72"	1 11/16"- 12 UN	1 11/16"- 12 UN	1 9/16"	2 3/8"	SZ-20-002SK-A
SZ-S24M-S24F	4.92"	3.19"	2.00"- 12 UN	2.00"- 12 UN	1 7/8"	2 3/4"	SZ-24-002SK-A



MALE JIC (37° FLARE) - MALE JIC (37° FLARE) BULKHEAD

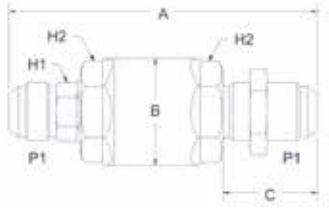

PART NU.	A	B	C	P1	H1	H2	SEAL KIT
SZ-J06M-J06MB	3.71"	1.22"	1.25"	9/16" - 18 UNF	1/2"	1"	SZ-06-001SK-A
SZ-J08M-J08MB	4.63"	1.47"	1.50"	3/4" - 16 UNF	11/16"	1 1/4"	SZ-08-001SK-A
SZ-J12M-J12MB	5.69"	1.97"	1.75"	1 1/16" - 12 UN	15/16"	1 5/8"	SZ-12-001SK-A
SZ-J16M-J16MB	6.31"	2.22"	1.88"	1 5/16" - 12 UN	1 3/16"	1 7/8"	SZ-16-001SK-A
SZ-J20M-J20MB	6.94"	2.72"	2"	1 5/8" - 12 UN	1 1/2"	2 3/8"	SZ-20-001SK-A

MALE ORFS (O-RING FACE SEAL) - MALE ORFS BULKHEAD

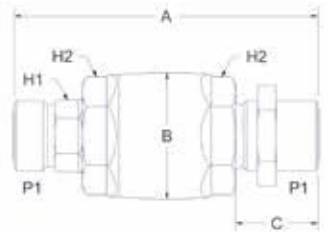

PART NU.	A	B	C	P1	H1	H2	SEAL KIT
SZ-S06M-S06MB	3.62"	1.35"	1.28"	11/16" - 16 UNF	5/8"	1 1/8"	SZ-06-002SK-A
SZ-S08M-S08MB	4.25"	1.53"	1.31"	13/16" - 12 UNF	3/4"	1 5/16"	SZ-08-002SK-A
SZ-S12M-S12MB	5.25"	2.09"	1.41"	1 3/16" - 12 UN	1 1/16"	1 3/4"	SZ-12-002SK-A
SZ-S16M-S16MB	5.88"	2.31"	1.56"	1 7/16" - 12 UN	1 5/16"	2"	SZ-16-002SK-A

MALE METRIC (DIN 3852) - FEMALE BSPP

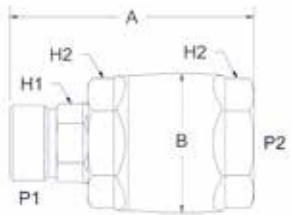

PART NU.	A	B	C	P1	H1	H2	SEAL KIT
SZ-M20SM-P08F	2.95"	1.53"	M20 X 1.5	G 1/2	3/4"	1 5/16"	SZ-08-002SK-A
SZ-M30SM-P12F	3.77"	2.09"	M30 X 2.0	G 3/4	1 1/16"	1 3/4"	SZ-12-002SK-A
SZ-M36SM-P16F	4.27"	2.34"	M36 X 2.0	G 1	1 5/16"	2"	SZ-16-002SK-A
SZ-M42SM-P20F	4.57"	2.72"	M42 X 2.0	G 1 1/4	1 9/16"	2 3/8"	SZ-20-001SK-A



MALE METRIC (DIN 3852) - FEMALE ORFS (O-RING FACE SEAL)

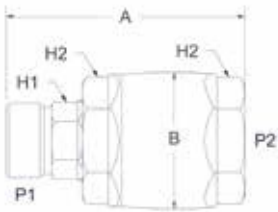

PART NU.	A	B	P1	P2	H1	H2	SEAL KIT
SZ-M30SM-S12F	3.83"	2.31"	M30 X 2.0	1 3/16"- 12 UN	1 1/16"	1 3/4"	SZ-12-002SK-A
SZ-M36SM-S16F	4.33"	2.31"	M36 X 2.0	1 7/16"- 12 UN	1 5/16"	2"	SZ-16-002SK-A
SZ-M42SM-S20F	4.70"	2.72"	M42 X 2.0	1 11/16"- 12 UN	1 9/16"	2 3/8"	SZ-20-001SK-A

MALE METRIC - MALE METRIC (DIN 3852)

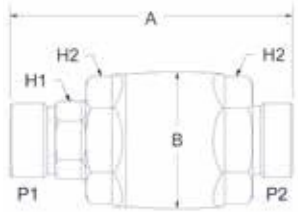

PART NU.	A	B	P1	P2	H1	H2	SEAL KIT
SZ-M24SM-M24SM	3.74"	1.86"	M24 X 1.5	M24 X 1.5	15/16"	1 5/8"	SZ-10-002SK-A
SZ-M30SM-M30SM	4.75"	2.09"	M30 X 2.0	M30 X 2.0	1 1/16"	1 3/4"	SZ-12-002SK-A
SZ-M30SM-M36SM	4.75"	2.09"	M30 X 2.0	M30 X 2.0	1 1/16"	1 3/4"	SZ-12-002SK-A
SZ-M30SM-M42SM	4.75"	2.09"	M30 X 2.0	M30 X 2.0	1 1/16"	1 3/4"	SZ-12-002SK-A
SZ-M36SM-M36SM	5.94"	2.40"	M36 X 2.0	M36 X 2.0	1 5/16"	2"	SZ-16-002SK-A
SZ-M42SM-M42SM	7.08"	2.88"	M42 X 2.0	M42 X 2.0	1 9/16"	2 3/8"	SZ-20-001SK-A

MALE METRIC - MALE METRIC BULKHEAD (DIN 3852)

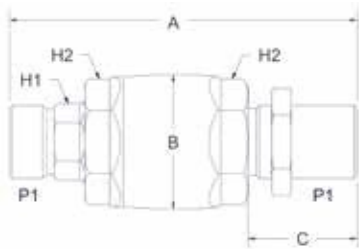

PART NU.	A	B	C	P1	H1	H2	SEAL KIT
SZ-M30SM-M30SMB	5.39"	2.09"	1.57	M30 X 2.0	1 1/16"	1 3/4"	SZ-12-002SK-A
SZ-M36SM-M36SMB	5.94"	2.40"	1.61	M36 X 2.0	1 5/16"	2"	SZ-16-002SK-A
SZ-M42SM-M42SMB	7.08"	2.88"	2.52	M42 X 2.0	1 9/16"	2 3/8"	SZ-20-001SK-A





6. 90° SWIVELS STANDARD SERIES

Meet the wide range of 90° Swivel- standard series, designed with the highest standard of durability. Taimi's unique ball-less technology brings reliability to your hydraulic system increasing service life and cutting out leakages. This means higher productivity and lower operating costs.

WHY CHOOSE TAIMI 90° SWIVELS - STANDARD SERIES?

- **Patented ball-less design**
- **No snap ring, will not dismantle**
- **Triple Seal Protection™**
- **Pressure Spikes Protection™**
- **Easy and quick to repack**
- **Great side loads resistance**
- **A product that pays back: less leaking and better wear resistance**

Hidrotema



WORLDWIDE DISTRIBUTION

Part numbers in orange
are usually in stock.

Other products are
manufactured to order

HOW TO ORDER

SZ90	J	12	M	B	12	F
90° SWIVEL DESIGNATOR	HOSE CONNECTION TYPE J = JIC (37°) FLARE F = NPT P = BSPP S = ORFS (O-RING FACE SEAL) M = METRIC	HOSE SIZE	SHANK CONFIGURATION M = MALE	HOUSING HOSE CONNECTION TYPE J = JIC (37°)FLARE B = SAE (O-RING BOSS) F = NPT P = BSPP S = ORFS (O-RING FACE SEAL) M = METRIC	SHANK SIZE 1/16 of an inch	HOUSING CONFIGURATION M = MALE F = FEMALE



MALE PIPE (NPT) - FEMALE PIPE (NPT)

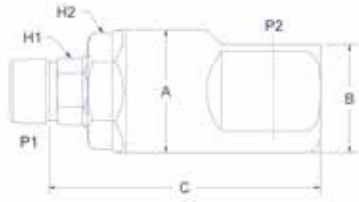

PART NU.	A	B	C	P1	P2	H1	H2	SEAL KIT
SZ90-F06M-F06F	1.35"	1.21"	2.62"	3/8" NPT	3/8" NPT	0.63"	1.12"	SZ-06-002SK-A
SZ90-F08M-F08F	1.53"	1.33"	3.31"	1/2" NPT	1/2" NPT	0.75"	1.31"	SZ-08-002SK-A
SZ90-F12M-F12F	1.97"	1.74"	4.34"	3/4" NPT	3/4" NPT	0.94"	1.63"	SZ-12-001SK-A
SZ90-F16M-F16F	2.22"	1.92"	4.88"	1" NPT	1" NPT	1.19"	1.88"	SZ-16-001SK-A

MALE PIPE (NPT) -
FEMALE O-RING BOSS (ORB) / SAE J1926-3

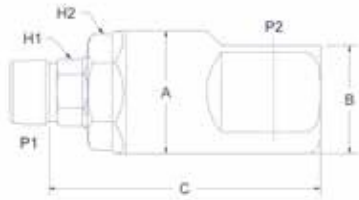

PART NU.	A	B	C	P1	P2	H1	H2	SEAL KIT
SZ90-F08M-B08F	1.53"	1.33"	3.31"	1/2" NPT	SAE 08	0.75"	1.31"	SZ-08-002SK-A
SZ90-F12M-B12F	1.97"	1.74"	4.34"	3/4" NPT	SAE 12	0.94"	1.63"	SZ-12-001SK-A
SZ90-F16M-B16F	2.22"	1.92"	4.88"	1" NPT	SAE 16	1.19"	1.88"	SZ-16-001SK-A
SZ90-F20M-B20F	2.72"	2.37"	5.84"	1 1/4" NPT	SAE 20	1.50"	2.38"	SZ-20-001SK-A

MALE PIPE (NPT) - MALE PIPE (NPT)

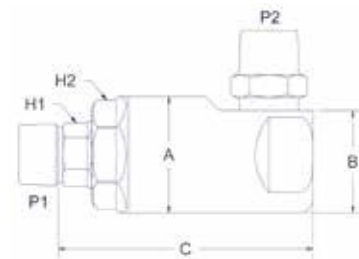

PART NU.	A	B	C	P1	P2	H1	H2	SEAL KIT
SZ90-F08M-F08M	1.53"	2.14"	3.31"	1/2" NPT	1/2" NPT	0.75"	1.31"	SZ-08-002SK-A
SZ90-F12M-F12M	1.97"	2.88"	4.34"	3/4" NPT	3/4" NPT	0.94"	1.63"	SZ-12-001SK-A
SZ90-F16M-F16M	2.22"	3.25"	4.88"	1" NPT	1" NPT	1.19"	1.88"	SZ-16-001SK-A
SZ90-F20M-F20M	2.72"	3.80"	5.84"	1 1/4" NPT	1 1/4" NPT	1.50"	2.38"	SZ-20-001SK-A

MALE PIPE (NPT) - MALE JIC (37° FLARE)

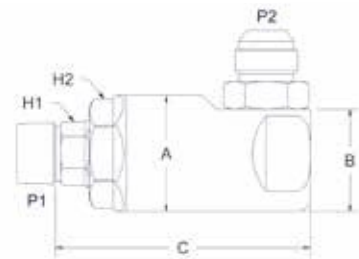

PART NU.	A	B	C	P1	P2	H1	H2	SEAL KIT
SZ90-F08M-J08M	1.53"	2.33"	3.31"	1/2" NPT	3/4" - 16 UNF	0.75"	1.31"	SZ-08-002SK-A
SZ90-F12M-J12M	1.97"	3.07"	4.34"	3/4" NPT	1 1/16" - 12 UN	0.94"	1.63"	SZ-12-001SK-A
SZ90-F16M-J16M	2.22"	3.31"	4.88"	1" NPT	1 5/16" - 12 UN	1.19"	1.88"	SZ-16-001SK-A
SZ90-F20M-J20M	2.72"	3.91"	5.84"	1 1/4" NPT	1 5/8" - 12 UN	1.50"	2.38"	SZ-20-001SK-A



MALE PIPE (NPT) -
MALE ORFS (O-RING FACE SEAL)

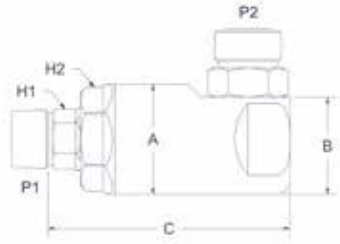

PART NU.	A	B	C	P1	P2	H1	H2	SEAL KIT
SZ90-F08M-S08M	1.53"	2.17"	3.31"	1/2" NPT	13/16" - 16 UNF	0.75"	1.31"	SZ-08-002SK-A
SZ90-F12M-S12M	1.97"	2.93"	4.34"	3/4" NPT	1 3/16" - 12 UN	0.94"	1.63"	SZ-12-001SK-A
SZ90-F16M-S16M	2.22"	3.17"	4.88"	1" NPT	1 7/16" - 12 UN	1.19"	1.88"	SZ-16-001SK-A
SZ90-F20M-S20M	2.72"	3.70"	5.84"	1 1/4" NPT	1 11/16" - 12 UN	1.50"	2.38"	SZ-20-001SK-A

MALE JIC (37° FLARE) -
FEMALE O-RING BOSS (ORB) / SAE J1926-3

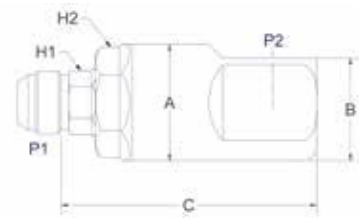

PART NU.	A	B	C	P1	P2	H1	H2	SEAL KIT
SZ90-J06M-B06F	1.22"	1.09"	2.53"	9/16" - 18 UNF	SAE 06	0.50"	1.00"	SZ-06-001SK-A
SZ90-J08M-B08F	1.47"	1.30"	3.28"	3/4" - 16 UNF	SAE 08	0.69"	1.25"	SZ-08-001SK-A
SZ90-J12M-B12F	1.97"	1.74"	4.34"	1 1/16" - 12 UN	SAE 12	0.94"	1.63"	SZ-12-001SK-A
SZ90-J16M-B16F	2.22"	1.92"	4.88"	1 5/16" - 12 UN	SAE 16	1.19"	1.88"	SZ-16-001SK-A
SZ90-J20M-B20F	2.72"	2.37"	5.84"	1 5/8" - 12 UN	SAE 20	1.50"	2.38"	SZ-20-001SK-A

MALE JIC (37° FLARE) - MALE JIC (37° FLARE)

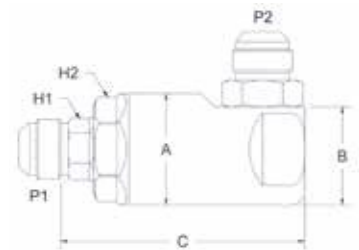

PART NU.	A	B	C	P1	P2	H1	H2	SEAL KIT
SZ90-J06M-J06M	1.22"	1.97"	2.53"	9/16" - 18 UNF	9/16" - 18 UNF	0.50"	1.00"	SZ-06-001SK-A
SZ90-J08M-J08M	1.47"	2.30"	3.28"	3/4" - 16 UNF	3/4" - 16 UNF	0.69"	1.25"	SZ-08-001SK-A
SZ90-J12M-J12M	1.97"	3.07"	4.34"	1 1/16" - 12 UN	1 1/16" - 12 UN	0.94"	1.63"	SZ-12-001SK-A
SZ90-J16M-J16M	2.22"	3.31"	4.88"	1 5/16" - 12 UN	1 5/16" - 12 UN	1.19"	1.88"	SZ-16-001SK-A
SZ90-J20M-J20M	2.72"	3.91"	5.84"	1 5/8" - 12 UN	1 5/8" - 12 UN	1.50"	2.38"	SZ-20-001SK-A

MALE JIC (37° FLARE) - MALE PIPE (NPT)

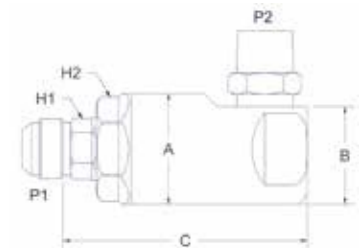

PART NU.	A	B	C	P1	P2	H1	H2	SEAL KIT
SZ90-J06M-F06M	1.22"	1.88"	2.53"	9/16" - 18 UNF	3/8" NPT	0.50"	1.00"	SZ-06-001SK-A
SZ90-J08M-F08M	1.47"	2.11"	3.28"	3/4" - 16 UNF	1/2" NPT	0.69"	1.25"	SZ-08-001SK-A
SZ90-J12M-F12M	1.97"	2.88"	4.34"	1 1/16" - 12 UN	3/4" NPT	0.94"	1.63"	SZ-12-001SK-A
SZ90-J16M-F16M	2.22"	3.25"	4.88"	1 5/16" - 12 UN	1" NPT	1.19"	1.88"	SZ-16-001SK-A
SZ90-J20M-F20M	2.72"	3.80"	5.84"	1 5/8" - 12 UN	1 1/4" NPT	1.50"	2.38"	SZ-20-001SK-A



**MALE JIC (37° FLARE) -
MALE ORFS (O-RING FACE SEAL)**

PART NU.	A	B	C	P1	P2	H1	H2	SEAL KIT
SZ90-J06M-S06M	1.22"	1.88"	2.53"	9/16" - 18 UNF	11/16" - 16 UNF	0.50"	1.00"	SZ-06-001SK-A
SZ90-J08M-S08M	1.47"	2.14"	3.28"	¾" - 16 UNF	13/16" - 16 UNF	0.69"	1.25"	SZ-08-001SK-A
SZ90-J12M-S12M	1.97"	2.93"	4.34"	1 1/16" - 12 UN	1 3/16" - 12 UN	0.94"	1.63"	SZ-12-001SK-A
SZ90-J16M-S16M	2.22"	3.17"	4.88"	1 5/16" - 12 UN	1 7/16" - 12 UN	1.19"	1.88"	SZ-16-001SK-A
SZ90-J20M-S20M	2.72"	3.70"	5.84"	1 5/8" - 12 UN	1 11/16" - 12 UN	1.50"	2.38"	SZ-20-001SK-A

MALE JIC (37° FLARE) - MALE BSPP

PART NU.	A	B	C	P1	P2	H1	H2	SEAL KIT
SZ90-J06M-P06M	1.22"	1.81"	2.53"	9/16" - 18 UNF	G 3/8	0.50"	1.00"	SZ-06-001SK-A
SZ90-J08M-P08M	1.47"	2.09"	3.28"	¾" - 16 UNF	G 1/2	0.69"	1.25"	SZ-08-001SK-A
SZ90-J12M-P12M	1.97"	2.80"	4.34"	1 1/16" - 12 UN	G 3/4	0.94"	1.63"	SZ-12-001SK-A
SZ90-J16M-P16M	2.22"	3.06"	4.88"	1 5/16" - 12 UN	G 1	1.19"	1.88"	SZ-16-001SK-A
SZ90-J20M-P20M	2.72"	3.82"	5.84"	1 5/8" - 12 UN	G 1 1/4	1.50"	2.38"	SZ-20-001SK-A

**MALE ORFS (O-RING FACE SEAL) -
FEMALE O-RING BOSS (ORB) / SAE J1926-3**

PART NU.	A	B	C	P1	P2	H1	H2	SEAL KIT
SZ90-S08M-B08F	1.53"	1.33"	3.34"	13/16" - 16 UNF	SAE 08	0.75"	1.31"	SZ-08-002SK-A
SZ90-S12M-B12F	2.09"	1.89"	4.34"	1 3/16" - 12 UN	SAE 12	1.06"	1.75"	SZ-12-002SK-A
SZ90-S16M-B16F	2.34"	2.05"	5.00"	1 7/16" - 12 UN	SAE 16	1.31"	2.00"	SZ-16-002SK-A
SZ90-S20M-B20F	2.88"	2.37"	5.84"	1 11/16" - 12 UN	SAE 20	1.56"	2.38"	SZ-20-002SK-A

**MALE ORFS (O-RING FACE SEAL) -
MALE ORFS (O-RING FACE SEAL)**

PART NU.	A	B	C	P1	P2	H1	H2	SEAL KIT
SZ90-S08M-S08M	1.53"	2.17"	3.34"	13/16" - 16 UNF	13/16" - 16 UNF	0.75"	1.31"	SZ-08-002SK-A
SZ90-S12M-S12M	2.09"	3.09"	4.34"	1 3/16" - 12 UN	1 3/16" - 12 UN	1.06"	1.75"	SZ-12-002SK-A
SZ90-S16M-S16M	2.34"	3.30"	5.00"	1 7/16" - 12 UN	1 7/16" - 12 UN	1.31"	2.00"	SZ-16-002SK-A
SZ90-S20M-S20M	2.88"	3.70"	5.84"	1 11/16" - 12 UN	1 11/16" - 12 UN	1.56"	2.38"	SZ-20-002SK-A



**MALE ORFS (O-RING FACE SEAL) -
MALE JIC (37° FLARE)**

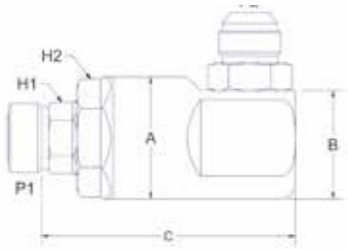

PART NU.	A	B	C	P1	P2	H1	H2	SEAL KIT
SZ90-S08M-J08M	1.53"	2.17"	3.34"	13/16" - 16 UNF	3/4" - 16 -UNF	0.75"	1.31"	SZ-08-002SK-A
SZ90-S12M-J12M	2.09"	3.22"	4.34"	1 3/16" - 12 UN	1 1/16" - 12 UN	1.06"	1.75"	SZ-12-002SK-A
SZ90-S16M-J16M	2.34"	3.44"	5.00"	1 7/16" - 12 UN	1 5/16" - 12 UN	1.31"	2.00"	SZ-16-002SK-A
SZ90-S20M-J20M	2.88"	3.91"	5.84"	1 11/16"-12 UN	1 5/8" - 12 UN	1.56"	2.38"	SZ-20-002SK-A

**MALE ORFS (O-RING FACE SEAL) -
MALE PIPE (NPT)**

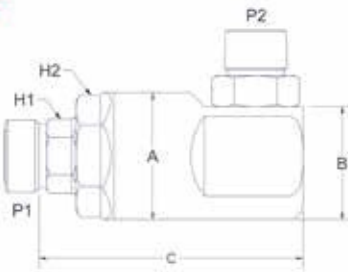

PART NU.	A	B	C	P1	P2	H1	H2	SEAL KIT
SZ90-S08M-F08M	1.53"	2.17"	3.34"	13/16" - 16 UNF	1/2" NPT	0.75"	1.31"	SZ-08-002SK-A
SZ90-S12M-F12M	2.09"	3.02"	4.34"	1 3/16" - 12 UN	3/4" NPT	1.06"	1.75"	SZ-12-002SK-A
SZ90-S16M-F16M	2.34"	3.38"	5.00"	1 7/16" - 12 UN	1" NPT	1.31"	2.00"	SZ-16-002SK-A
SZ90-S20M-F20M	2.88"	3.80"	5.84"	1 11/16"-12 UN	1 1/4" NPT	1.56"	2.38"	SZ-20-002SK-A

MALE ORFS (O-RING FACE SEAL) - MALE BSPP

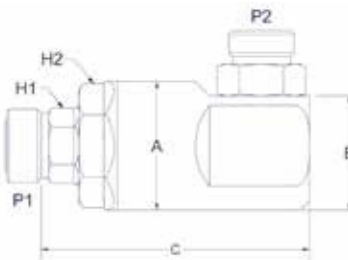

PART NU.	A	B	C	P1	P2	H1	H2	SEAL KIT
SZ90-S08M-P08M	1.53"	2.17"	3.34"	13/16" - 16 UNF	G 1/2	0.75"	1.31"	SZ-08-002SK-A
SZ90-S12M-P12M	2.09"	2.95"	4.34"	1 3/16" - 12 UN	G 3/4	1.06"	1.75"	SZ-12-002SK-A
SZ90-S16M-P16M	2.34"	3.19"	5.00"	1 7/16" - 12 UN	G 1	1.31"	2.00"	SZ-16-002SK-A
SZ90-S20M-P20M	2.88"	3.82"	5.84"	1 11/16"-12 UN	G 1 1/4	1.56"	2.38"	SZ-20-002SK-A

**MALE BSPP -
FEMALE O-RING BOSS (ORB) / SAE J1926-3**

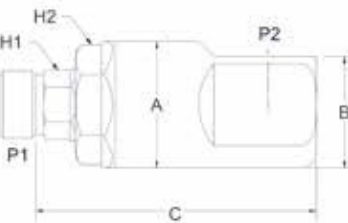

PART NU.	A	B	C	P1	P2	H1	H2	SEAL KIT
SZ90-P08M-B08F	1.53"	1.33"	3.34"	G 1/2	SAE 08	0.75"	1.31"	SZ-08-002SK-A
SZ90-P12M-B12F	1.97"	1.89"	4.34"	G 3/4	SAE 12	0.94"	1.63"	SZ-12-001SK-A
SZ90-P16M-B16F	2.22"	2.05"	5.00"	G 1	SAE 16	1.19"	1.88"	SZ-16-001SK-A
SZ90-P20M-B20F	2.72"	2.37"	5.84"	G 1 1/4	SAE 20	1.50"	2.38"	SZ-20-001SK-A



MALE BSPP - MALE BSPP

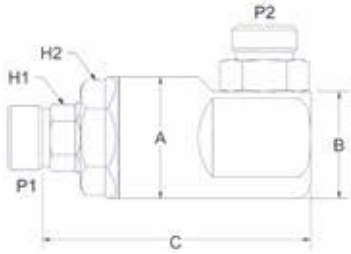

PART NU.	A	B	C	P1	P2	H1	H2	SEAL KIT
SZ90-P08M-P08M	1.53"	2.17"	3.34"	G 1/2	G 1/2	0.75"	1.31"	SZ-08-002SK-A
SZ90-P12M-P12M	1.97"	2.80"	4.34"	G 3/4	G 3/4	0.94"	1.63"	SZ-12-001SK-A
SZ90-P16M-P16M	2.22"	3.06"	4.88"	G 1	G 1	1.19"	1.88"	SZ-16-001SKA
SZ90-P20M-P20M	2.73"	3.82"	5.84"	G 1 1/4	G 1 1/4	1.50"	2.38"	SZ-20-001SK-A

MALE BSPP - MALE JIC (37° FLARE)

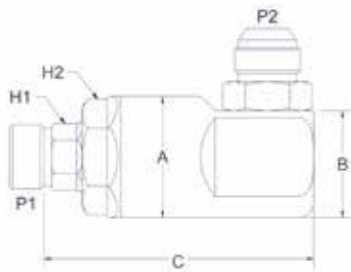

PART NU.	A	B	C	P1	P2	H1	H2	SEAL KIT
SZ90-P08M-J08M	1.53"	2.17"	3.34"	G 1/2	3/4" - 16 UNF	0.75"	1.31"	SZ-08-002SK-A
SZ90-P12M-J12M	1.97"	3.07"	4.34"	G 3/4	1 1/16" - 12 UN	0.94"	1.63"	SZ-12-001SK-A
SZ90-P16M-J16M	2.22"	3.31"	4.88"	G 1	1 5/16" - 12 UN	1.19"	1.88"	SZ-16-001SK-A
SZ90-P20M-J20M	2.73"	3.91"	5.84"	G 1 1/4	1 5/8" - 12 UN	1.50"	2.38"	SZ-20-001SK-A

MALE BSPP - MALE ORFS (O-RING FACE SEAL)

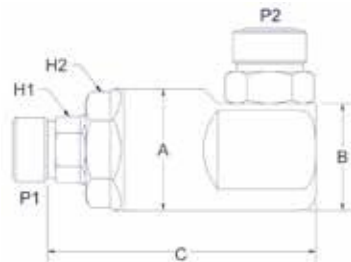

PART NU.	A	B	C	P1	P2	H1	H2	SEAL KIT
SZ90-P08M-S08M	1.53"	2.17"	3.34"	G 1/2	13/16" - 16 UNF	0.75"	1.31"	SZ-08-002SK-A
SZ90-P12M-S12M	1.97"	2.93"	4.34"	G 3/4	1 3/16" - 12 UN	0.94"	1.63"	SZ-12-001SK-A
SZ90-P16M-S16M	2.22"	3.17"	4.88"	G 1	1 7/16" - 12 UN	1.19"	1.88"	SZ-16-001SK-A
SZ90-P20M-S20M	2.72"	3.70"	5.84"	G 1 1/4	1 11/16" - 12 UN	1.50"	2.38"	SZ-20-001SK-A



8. DUAL SWIVEL MANIFOLD “A” SERIES



The Dual Swivel Manifold houses two Screw-in Cartridge Swivels. Designed to be bolted or welded together, they are used in multiple applications, 90° or 45° fittings can be installed on both the swivel and static sides of the manifold.

WHY CHOOSE TAIMI DUAL SWIVEL MANIFOLDS?

- **Pressure Spikes Protection™**
- **Easy and quick to repack**
- **Triple Seal Protection™**
- **Short and sturdy swivel port**
- **Sturdier than bulkhead assemblies**
- **Patented ball-less design**
- **Cannot be pulled apart**
- **High side loads and wear resistance**
- **Custom solutions available**



Hidrotema



ENDLESS POSSIBILITIES



**Part numbers in orange
are usually in stock.**

**Other products are
manufactured to order.**

HOW TO ORDER

SM2A	J	12	501
DUAL SWIVEL MANIFOLD DESIGNATOR	HOSE CONNECTION TYPE J = JIC (37°)FLARE P = BSPP S = ORFS (O-RING FACE SEAL) F = NPT M = METRIC	SHANK SIZE	ASSEMBLY NUMBER



DUAL / MALE JIC (37° FLARE) - MALE JIC (37° FLARE)

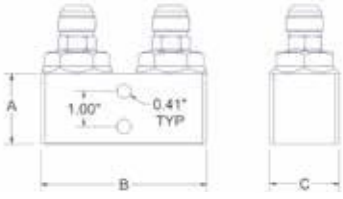

PART NU.	A	B	C	D	P1	P2	SEAL KIT
SM2A-J06-503	1.5"	3.40"	1.5"	3.50"	9/16"- 18 UNF	9/16" - 18 UNF	SZ-06-001SK-A
SM2A-J08-501	1.63"	4.45"	1.63"	3.69"	¾"- 16 UNF	¾"- 16 UNF	SZ-08-001SK-A
SM2A-J10-501	1.88"	4.60"	1.88"	4.50"	7/8"- 14 UNF	7/8" - 14 UNF	SZ-10-001SK-A
SM2A-J12-501	2.00"	5.35"	2.00"	4.50"	1 1/16"- 12 UN	1 1/16" - 12 UN	SZ-12-001SK-A
SM2A-J16-501	2.25"	6.31"	2.25"	5.00"	1 5/16"- 12 UN	1 5/16" - 12 UN	SZ-16-001SK-A
SM2A-J1612-501	2.25"	6.31"	2.25"	5.00"	1 5/16"- 12 UN	1 5/16" - 12 UN	SZ-16-001SK-A SZ-12-001SK-A
SM2A-J20-501	2.75"	7.13"	2.75"	6.12"	1 5/8"- 12 UN	1 5/8" - 12 UN	SZ-20-001SK-A

DUAL / MALE JIC (37° FLARE) - MALE ORFS (O-RING FACE SEAL / FLAT FACE O-RING)

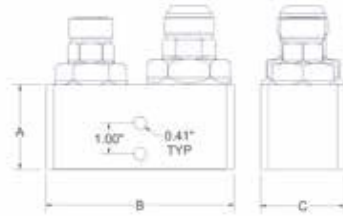

PART NU.	A	B	C	D	P1	P2	SEAL KIT
SM2A-J20S16-501	2.75"	6.84"	2.75"	6.13"	1 5/8"-12 UN 1 7/16"-12 UN	1 5/8"-12 UN 1 7/16"-12 UN	SZ-20-001SK-A SZ-16-002SK-A

DUAL / MALE PIPE (NPT) - MALE PIPE (NPT)

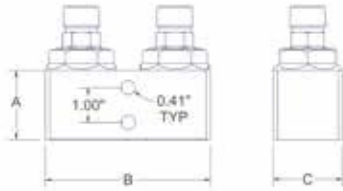

PART NU.	A	B	C	D	P1	P2	SEAL KIT
SM2A-F08-501	1.63"	4.10"	1.63"	3.69"	1/2» NPT	1/2» NPT	SZ-08-002SK-A
SM2A-F12-501	2.00"	5.05"	2.00"	4.50"	3/4" NPT	3/4" NPT	SZ-12-001SK-A
SM2A-F16-501	2.25"	5.59"	2.25"	5.00"	1" NPT	1" NPT	SZ-16-001SK-A

DUAL / MALE BSPP - MALE BSPP

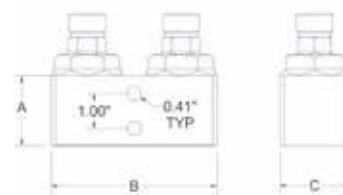

PART NU.	A	B	C	D	P1	P2	SEAL KIT
SM2A-P12-501	2.00"	5.14"	2.00"	4.50"	G 3/4	G 3/4	SZ-12-001SK-A
SM2A-P16-501	2.25"	5.86"	2.25"	5.00"	G 1	G 1	SZ-16-001SK-A



9. TAIMI RINGS

A simple, light and sturdy solution to support and route hoses while still allowing the complete relief of torsion during operations. They are a perfect complement to our swivel solutions for a reliable hose routing.



WHY CHOOSE TAIMI RINGS ?

- **Higher performance**
- **Cost savings on hoses**
- **Better hose grouping, control and support**
- **Increased operating time**
- **Less maintenance**
- **Reduced oil consumption**
- **Easy to set up and to access hoses**
- **Increased flexibility (no rigid hose section)**
- **Reduced pressure drop in the system**
- **Sustainable**



Hidrotema



HIGHER PERFORMANCE



HOW TO ORDER

**Part numbers in orange
are usually in stock.**

**Other products are
manufactured to order**

SHH	16	524P
TAIMI RINGS DESIGNATOR	HOSE SIZES	ASSEMBLY DESIGNATOR



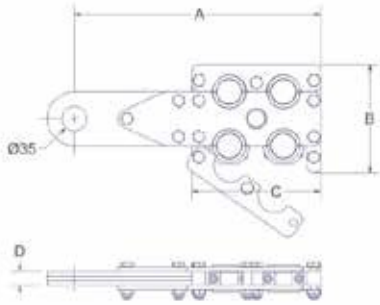

FORESTRY KITS

PART NU.	A	B	C	D	HOSES SIZE
SHH-16-524P	345,5	152,4	180,3	19,1	4x 16, 1x 04
SHH-16-524K	345,5	152,4	180,3	19,1	4x 16, 1x 04

*Dimensions are in mm

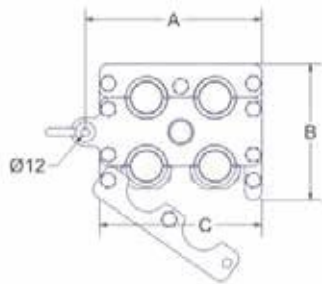

PART NU.	A	B	C	D	HOSES SIZE
SHH-16-524SPC	196,2	152,4	180,3	19,1	4x 16, 1x 04
SHH-1608-526W	345,5	152,4	248,0	44,5	4x 16, 2x 08, 1x 04

*Dimensions are in mm

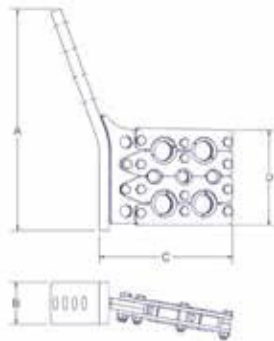

PART NU.	A	B	C	D	HOSES SIZE
SHH-1608-526SPC	271,7	152,4	248,0	19,1	4x 16, 2x 08, 1x 04
SHH-1684-527L	407,0	172,5	244,8	76,2	2x 16, 2x 1612, 1x 08, 2x 04

*Dimensions are in mm

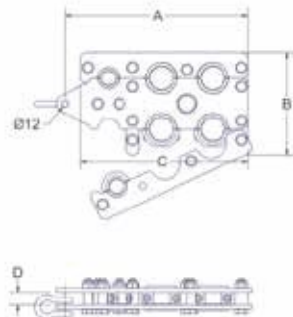

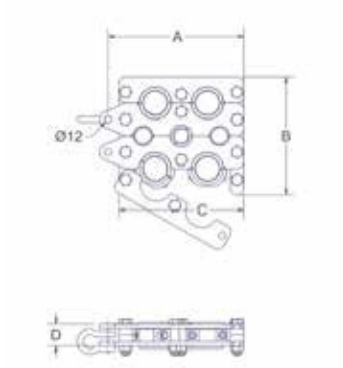

PART NU.	A	B	C	D	HOSES SIZE
SHH-1684-527LPC	196,2	172,5	180,3	76,2	2x 16, 2x 1612, 1x 08, 2x 04

*Dimensions are in mm

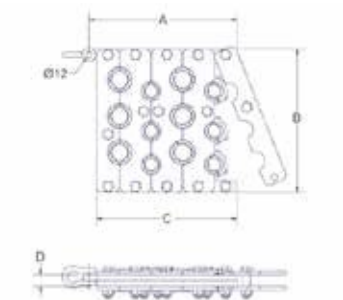

UNDERGROUND MINING JUMBOS & BOLTERS KITS

PART NU.	A	B	C	D	HOSES SIZE
SHH-1208-566S	246,2	238,1	233,3	19,1	6x 12, 6x 08
SHH-161208-515S	246,2	247,6	239,7	19,1	1x 16, 2x 12, 12x 08

*Dimensions are in mm

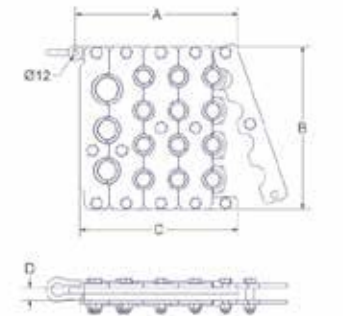



10. STRAP-WRAP

Strap-Wrap™ was developed and patented by Taimi to group and support hoses. Made out of flexible webbing, Strap-Wrap™ works well on long hose groups, taking the load off press fittings and on short hose groups, keeping plastic wrap from sliding down.

WHY CHOOSE TAIMI STRAP-WRAP?

- **Groups and protects hoses against stretching and tearing**
- **Can be solidly attached to both ends and will not shift during operation**
- **The double Strap-Wrap allows for the hose groups to be secured on several points along the line for the best possible routing**
- **Resistant material, no sensitivity to temperature variations**
- **Excellent visibility**
- **Can group as many hoses as needed**
- **Flexible and easy to install**



Hidrotema



SUSTAINABLE SOLUTIONS

STRAP-WRAPSM PATENTED



HOW TO ORDER

SW2	25	001
STRAP-WRAP - DESIGNATOR	WIDTH (1/10 INCH)	
SW1 = SINGLE STRAP SW2 = DOUBLE STRAP	AVAILABLE IN 2.5 INCH WIDTH or 50 mm	



Taimi's Strap-Wrap™ product is the combination of the single and the double straps. The double strap is used as the main support strap, while the single strap is woven into the double strap and around the hose group. It is easy to manipulate at any temperature. It is light and takes little space for shipping and storage. It gives great accessibility to the hoses, thus reducing the time required to inspect and replace them.

Setting up

The Strap-Wrap system contains three (3) items. The double (main support) strap, the attachment buckle, and the single strap that wraps around the hose group.

- 1- Measure the interior length of the hose group's curve to find the required length of double strap.**
- 2- Cut the double strap to the desire length and fasten attachment buckles to an end.**

You can melt the ends (just like with a nylon rope) to prevent the strap from unweaving. The distance between the buckles and the attachment points can vary depending on the application. You can secure the buckles on the equipment, using a piece of chain.

SINGLE STRAP

DOUBLE STRAP

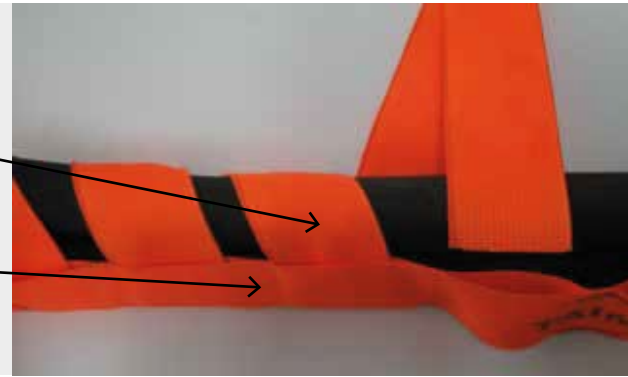

Note : Taimi supplies buckles to fit most types of equipment, usually using a piece of chain.

You can also use different ways to secure your set up.

- 3-Weave the single strap around the hose group and into the double strap. Near the buckle, double the single strap in the last loop before securing the single strap to the buckle. Once it is attached to one end, tighten your way back to the other end before fastening it, making a nice tight bundle.**



Once in place you do not have to remove it to access hoses; just release the ends and the first loop if needed to make the whole thing loose. This way, you can pull out a hose and replace it.

Taimi's double Strap-Wrap™ will also effectively keep plastic wraps from sliding down a hose group. Simply weave your spiral wrap into a short length of Taimi's Strap-Wrap™ and secure it to your machine.



11. CUSTOM PRODUCTS



Custom products are designed for specific applications and machines.

WHY CHOOSE TAIMI CUSTOM PRODUCTS ?

Cost savings up to 75% including :

- Hydraulic hoses
- Press fittings
- Live swivels
- Hydraulic oil
- Manpower
- Downtimes
-
-

Part numbers in orange are usually in stock.

Other products are manufactured to order



Hidrotema



11.1 SWIROLLS FOR LOGMAX HARVESTER HEADS



LENGTH : 13.25" - WIDTH : 9.66" - HEIGHT : 7.63"

WEIGHT : 51.5 LBS - SEAL KIT : SZ-SRL-301SK

U-BOLT LOCKING DEVICE : SRF-85-113

JIC CONFIGURATIONS

PART NU.	PORTS
SR4S-JJ-502	3 X J16, 1 X J12
SR4S-JJ-504	3 X J16, 1 X J08
SR4S-JJ-505	2 X J16, 2 X J12
SR4S-JJ-506	2 X J16, 1 X J12, 1 X J08
SR4S-JJ-520	2 X J20, 2 X J12
SR5-JJ-503	3 X J16, 2 X J12

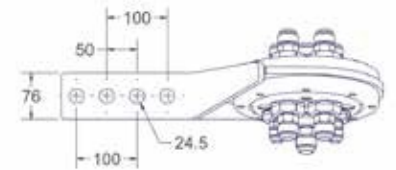
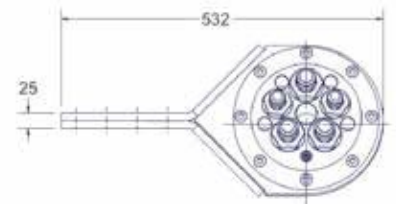

BSPB CONFIGURATIONS

PART NU.	PORTS
SR4S-PP-504	3 X P16, 1 X P08
SR4S-PP-505	2 X P16, 2 X P12
SR4S-PP-506	2 X P16, 1 X P12, 1 X P08
SR5-PP-506K	2 X P16, 2 X P12, 1 X P08
SR5-PP-507	2 X P16, 1 X P12, 2 X P08

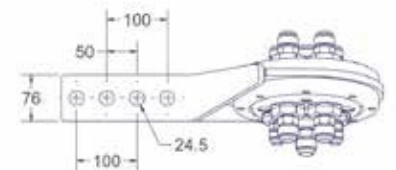
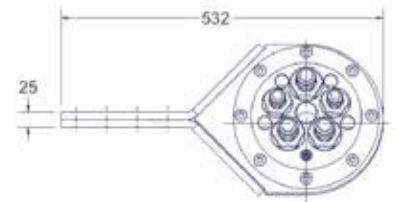

ORFS CONFIGURATION

PART NU.	PORTS
SR5-SS-506	1x S08, 1 x S12, 2 x S16



11.2 SWIROLLS FOR SOUTHSTAR HARVESTER HEADS

LENGTH : 13.25" - WIDTH : 9.66" - HEIGHT : 7.63"
 WEIGHT : 62.2 LBS - SEAL KIT : SZSRS-302SK
 U-BOLT LOCKING DEVICE : SRF-85-113

JIC CONFIGURATIONS

PART NU.	PORTS
SR4S-JS-503	2 X JIC 16, 2 X JIC 12

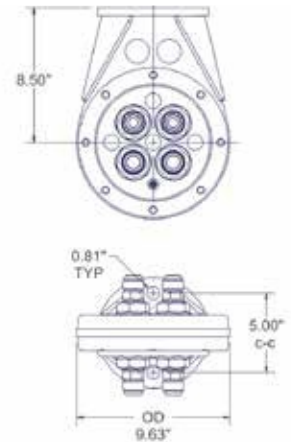

11.3 BLOCK FOR CATERPILLAR TRACK HARVESTERS BOOM

PART NU.	REFERENCE	A	B	C	PORTS	WEIGHT
SM4C-S201208-502	501HD Main Boom & 501HD Stick Boom	12.5"	2.20"	7.5"	3 X ORFS 20 3 X ORFS 12 3 X ORFS 08	52 Lbs
SM5F-J1208-504	Full Kit For CAT 501HD Boom	12.5"	2.20"	7.5"	2 X 3 X ORFS 20 3 X ORFS 12 3 X ORFS 08	104 Lbs

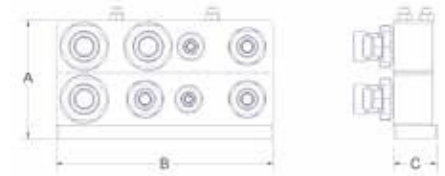

12. SEAL KIT REPLACEMENT

1. **Read the safety precautions in section 1 of the product catalog before going any further!**
2. **Relieve pressure before dismanteling hydraulic lines**
3. **Clean work space**
4. **Remove nut**
Pneumatic torque tool and vise recommended
5. **Remove seal kit** - Remove debris & clean grooves
6. **Install new seal kit**
7. **Assemble cartridge**
8. **Tighten**

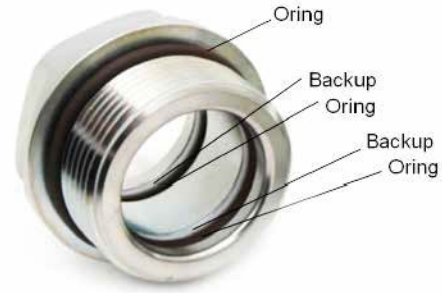

CARTRIDGE SWIVEL ASSEMBLY TORQUE

SIZES	FT-LBS	NM
06	125	170 Nm
08	215	290 Nm
10	300	405 Nm
12	390	530 Nm
16	490	665 Nm
20	800	1080 Nm
24	900	1215 Nm
32	1000	1350 Nm

Respect recommended torque

- Over-tightening may result in swivel failure
- Under-tightening may result in swivel dismantling

- Dry torque - Lubricate external o-ring



Swivel failure during operation can cause fluid to escape. Escaping fluid under pressure can penetrate skin causing serious injury or death. Always wear safety equipment before approaching hydraulic equipment under pressure

13. WARRANTY & LIMITATION OF LIABILITY

Every swivel product we carefully manufacture is reliable and leak resistant like no other you have ever used. Sure, there are important fine prints to our warranty which we invite you to read. But despite all the legal stuff below, please contact us if you experience an issue that you did not expect, at any moment.

Taimi products used under our specifications are guaranteed against defects in materials and workmanship for a period of 12 months or 2000 hours of use. Taimi's obligation under this warranty is limited to the repair or exchange of the defective product, at Taimi's option. This is the sole remedy for breach of warranty. Taimi will in no event be liable to anyone for lost profit, special, indirect, incidental, consequential or exemplary damages, whether based upon negligence, breach of warranty, strict liability or otherwise, nor for any sum in excess of the price received for the products for which liability is claimed.



This warranty is void if the defect is caused by improper installation, use or maintenance of the products. Products that have been modified are not covered under this warranty. Normal wear and tear, maintenance, seal kits and freight are not covered by this warranty. Any description of the products is for the sole purpose of identifying such products and shall not create an express warranty that the goods shall conform to such description. Buyer is solely responsible for determining the suitability of products sold hereunder for use by buyer. Taimi products should not be used as structural or load bearing components.

Some states do not allow the exclusion or limitation of incidental or consequential damages, and some states do not allow limitations on how long an implied warranty lasts, so the above limitation and exclusion may not apply to you. This warranty gives you specific legal rights, and you may also have other rights which vary from state to state.

All other warranties, express or implied, including, but not limited to warranties of merchantability and fitness for a particular purpose, are expressly disclaimed.

