

### Código

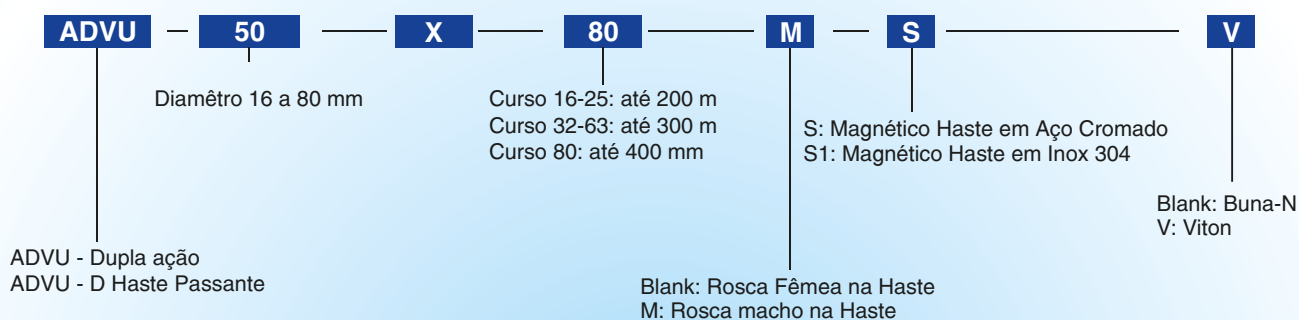

### Especificações

Diâmetro do Cilindro (mm)	16	20	25	32	40	50	63	80
Ação	Dupla Ação							
Pressão de Trabalho	1,2 - 10 BAR	1 - 10 BAR	0,8 - 10 BAR			0,6 - 10 BAR		
Pressão Máxima	13,5 BAR							
Velocidade	30 - 800 mm/s							
Rosca	M5				G 1/8			

Diâmetro	Cursos Padrões (mm)								
	20	25	30	40	50	60	80	100	
16	20	25	30	40	50				
20	20	25	30	40	50				
25	20	25	30	40	50				
32	20	25	30	40	50	60	80	100	
40	20	25	30	40	50	60	80	100	
50	20	25	30	40	50	60	80	100	
63	20	25	30	40	50	60	80	100	
80	20	25	30	40	50	60	80	100	



								HASTE AÇO CROMADO	
Ø	REPARO	Ø	CAMISAS	Ø	KITS	KITS VITON	KITS PASSANTE	Ø	CÓDIGO
16	REP16ADVU	16	CAM16AD	16	ADVU16	ADVU16V	ADVU16D	8mm	HACR08
20	REP20ADVU	20	CAM20AD	20	ADVU20	ADVU20V	ADVU20D	10mm	HACR10
25	REP25ADVU	25	CAM25AD	25	ADVU25	ADVU25V	ADVU25D	10mm	HACR10
32	REP32ADVU	32	CAM32AD	32	ADVU32	ADVU32V	ADVU32D	12mm	HACR32
40	REP40ADVU	40	CAM40AD	40	ADVU40	ADVU40V	ADVU40D	12mm	HACR32
50	REP50ADVU	50	CAM50AD	50	ADVU50	ADVU50V	ADVU50D	16mm	HACR40
63	REP63ADVU	63	CAM63AD	63	ADVU63	ADVU63V	ADVU63D	16mm	HACR40
80	REP80ADVU	80	CAM80AD	80	ADVU80	ADVU80V	ADVU80D	20mm	HACR50/63

**OBS.: CAMISAS, HASTES CONSULTAR LISTAS DE PREÇOS.  
MONTAMOS CILINDROS ESPECIAIS CONSULTE.**

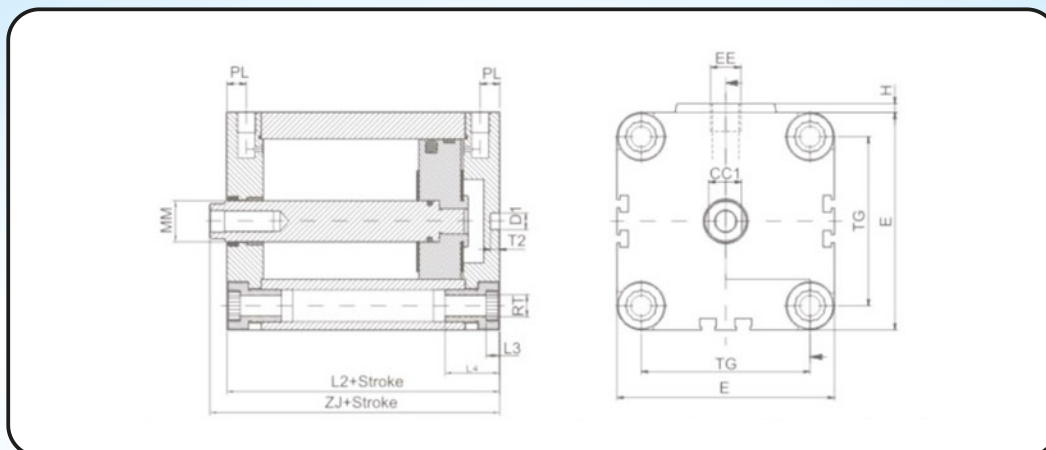

MODELO	TAMANHO	D1	E	EE	H	L2	L3	L4	øMM	PL	RT	T2	TG	ZJ	CC1
ADVU	16	6	29	M5	1	38	3	16	8	8	M4	4	18	42.5	7
	20	6	36	M5	1.5	38	4	18	10	8	M5	4	22	42.5	9
	25	6	40	M5	1.5	39.5	4	18	10	8	M5	4	26	45	9
	32	6	50	G 1/8	2	44.5	5	20	12	8	M6	4	32	50.5	10
	40	6	60	G 1/8	2.5	45.5	5	20	12	8	M6	4	42	52	10
	50	6	68	G 1/8	3	45.5	6	20	16	8	M8	4	50	53	13
	63	6	87	G 1/8	4	50	8	25	16	8	M10	4	62	57.5	13
	80	6	107	G 1/8	4	56	8	25	20	8.5	M10	4	82	64	17
100	6	128	G 1/4	5	66.5	8	25	35	10.5	M10	4	103	76.5	22	

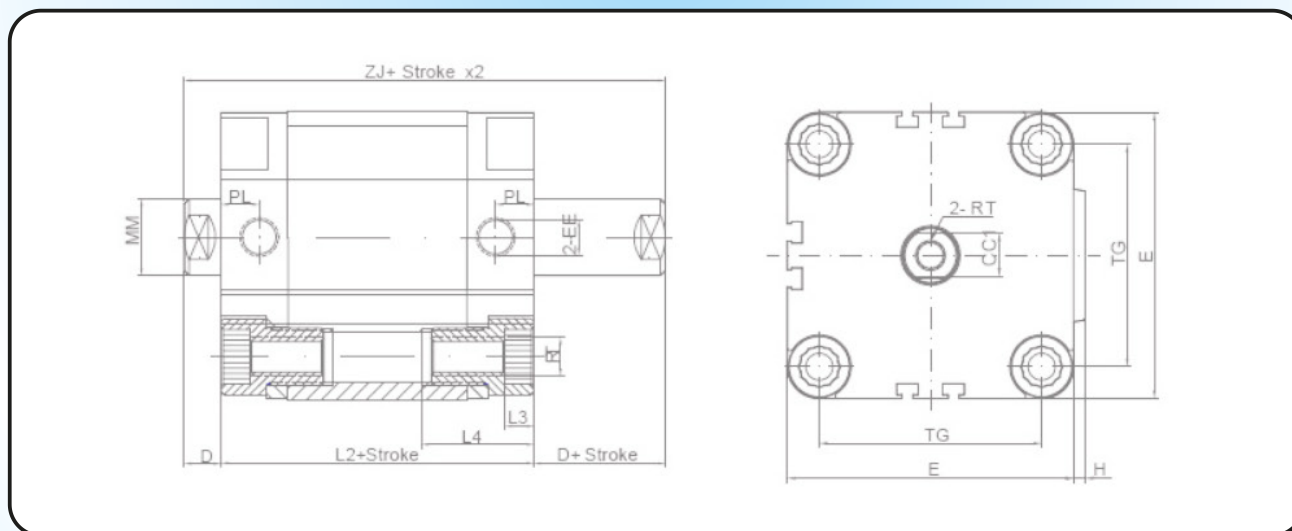

MODELO	TAMANHO	E	EE	H	L2	L3	L4	øMM	PL	RT	TG	ZJ	CC1	T2
ADVUD	16	29	M5	1	38	4	18.5	8	8	M4	18	44	6	6
	20	36	M5	1.5	38	4	18.5	10	8	M5	22	43.5	8	5.5
	25	40	M5	1.5	39.5	4	18.5	10	8	M5	26	46	8	6.5
	32	50	G 1/8	2	44.5	5	22	12	8	M6	32	51.5	10	7
	40	60	G 1/8	2.5	45.5	5	22	12	8	M6	42	52	10	6.5
	50	68	G 1/8	3	45.5	5	22	16	8	M8	50	54.5	14	8
	63	87	G 1/8	4	50	6	26	16	8	M10	62	58	14	8
	80	107	G 1/8	4	56	6	26	20	8.5	M10	82	64	17	8